

## LEDambient Trunk Light



**Universal LED trunk light with acceleration and brightness sensor**

For higher visibility in everyday situations



**Multi-function 2 in 1**

Applicable as trunk and torch light



**Easy car side fixation via magnet and additional mounting plate**

Strong magnet for a quick attachment



**2 years OSRAM guarantee<sup>1)</sup>** For precise conditions refer to: [www.osram.com/am-guarantee](http://www.osram.com/am-guarantee)

Powerful performance and exceptionally long service life



### 精确照明汽车内饰

Introducing the universal LEDambient Trunk Light, the perfect companion for your car's storage space. Packed with advanced features and designed to enhance your convenience, this versatile light will transform the way you use the trunk. Featuring an acceleration and brightness sensor, the trunk light boasts an automatic light function that activates as soon as you open the car trunk. Our light illuminates your trunk instantly, making it effortless to find what you need. With both automatic and manual functionality, you have complete control over the lighting. With a color temperature of up to 6,000K, the trunk light provides a bright and clear illumination, allowing you to see every detail in your trunk. Very practical: With its 2 in 1

## 产品数据表

multifunction, the light can be used as an inspection lamp and as a torch light. In addition, equipped with a rechargeable 1500mAh battery, the trunk light offers long-lasting performance. The included USB-C cable allows for convenient charging, ensuring you're always prepared. Thanks to the easy car side fixation via the magnet and additional mounting plate, an easy installation is included. Simply attach the light to your car's interior using the strong magnet or the included mounting plate, and you're ready to go. The powerful magnet ensures a secure attachment, so you never have to worry about the light falling or moving while you're on the road. Trust in the quality and durability of the universal LED trunk light - OSRAM provides a 2-year guarantee<sup>1)</sup>. 1) For precise conditions refer to: [www.osram.com/am-guarantee](http://www.osram.com/am-guarantee)

# 产品数据表

## 技术参数

### General Product Information

Order reference	LEDINT106
-----------------	-----------

### 电参数

标称功率	30.00 W
标称电压	3.7 V

### 光度数据

色温	6000 K
光通量	40 lm

### Physical Attributes & Dimensions

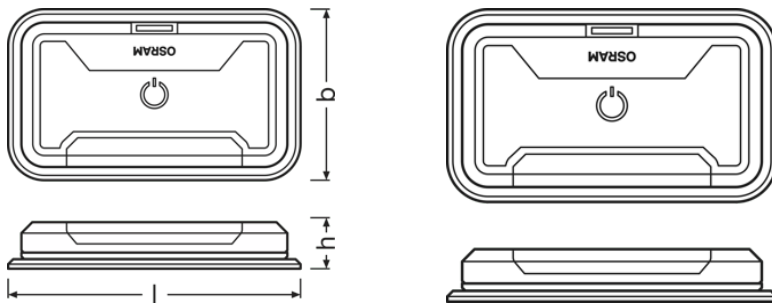

产品重量	100.00 g
长度	108.0 mm
宽度	17.5 mm
高度	63.0 mm

### 寿命

使用寿命 Tc	1000 hr
Guarantee	2 年

### 认证与标准

标准	CE
----	----

### Environmental & Regulatory Information

Information according Art. 33 of EU Regulation (EC) 1907/2006 (REACH)
---

## 产品数据表





Primary Article Identifier	4062172240062
Candidate List Substance 1	No declarable substances contained
Declaration No. in SCIP database	No declarable substances contained

## 物流数据

产品代码	产品描述	包装单位 ( 件/单位 )	尺寸 ( 长 x 宽 x 高 )	体积	毛重
4062172240062	LEDambient Trunk Light	纸盒 1	65 mm x 19 mm x 137 mm	0.17 dm <sup>3</sup>	141.00 g
4062172240079	LEDambient Trunk Light	箱 10	235 mm x 114 mm x 107 mm	2.87 dm <sup>3</sup>	1600.00 g

这里所提到的产品编码代表最小订购数量。一个整件包装含有一个或多个单一产品。请您在下单时，按一个或多个整件数下单。

## 下载数据

文件	
	User instruction GPRS_Safety symbols instructions
	User instruction LEDambient TRUNK LIGHT
	Movie application LEDambient Trunk Light LEDINT106 Produkt Video DE
	Movie application LEDambient Trunk Light LEDINT106 Product Video EN

### 安全建议

For detailed application information, please refer to the product data sheet and the user instruction

### 应用建议

更多详细应用信息和图形,请参阅产品数据表。

### 免责声明

更改恕不另行通知。遗漏错误不承担任何责任。总是确保使用最新的信息。

# OSRAM